

MUV
MOBILITY URBAN VEHICLE

MUV VIBE



USER MANUAL

UNLOCK THE FULL
POTENTIAL OF YOUR

WAY TO MUV.



CONGRATULATIONS ON YOUR NEW MUV E-BIKE!

Welcome to the MUV AUSTRALIA family! We're a proud, family-owned business passionate about creating top-quality electric bikes that prioritize safety, innovation, and exceptional ride experiences. We're always evolving to bring you the best products and excellence in customer service

As a new MUV eBike owner, you'll be pleased to know we offer a great warranty for your peace of mind (see our Terms and Conditions for details).

We value your feedback, so if there's anything we can improve, please let us know at admin@muvaustralia.com.au.

Join us on Instagram and Facebook to share your adventures and connect with other bike lovers! Don't forget to tag us using [@muv_electric](#) – we'd love to see your photos and videos!

USER MANUAL

TABLE OF CONTENTS

Diagram of e-bike specific components	3
Specification	3
Display	4
How to use	6
Battery	8
Charger	11
Important Notice Before Riding	13
Initial Assembly and Monthly Maintenance Checklist	13
WARNING	19
Terms & Condition	20
WARRANTY	25



DIAGRAM OF E-BIKE SPECIFIC COMPONENTS

1 Handlebar

2 Display

3 Front fork

4 Saddle

5 Tyre

6 Battery

7 Controller

8 Motor



SPECIFICATION

Frame: 20 Inch aluminium-alloy

Brake: F/R hydraulic Disc Brake

Derailleur: Shimano 7 speed

Charger: AC 110V-240V Smart Charge

Sensor: Speed sensor 1:1

Charge time: 4-6 hours

Display: LCD with 5 mode

Max speed: 25km/h

Battery: Lithium battery 48V 15.6Ah

Range: 65KM

Motor: 250W brushless

Max loading: 120kg

DISPLAY

1. LCD INSTRUCTIONS

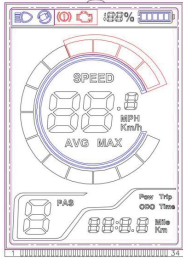

The figure of LCD display see below:

1.1 Head light



USB charging remind



Braking condition



1.2 Battery capacity



1.3 ODO: total distance Trip: DST trip distance

Pow: digital voltage Time:riding time



1.4 Mode: 6km push Cruise control



1.5 Speed

MAX:max speed

AVG: averagte speed



DISPLAY



2. FUNCTIONAL DESCRIPTION



2.1 POWER ON/OFF

Press and hold  button for 1 second can turn on/off the display. The display will automatically shut down when there is no operate & ride for 5 minutes.

2.2 PAS OPERATING

Short press   button can change the PAS level. Top PAS level is 5, 0 for neutral. Level quantities can be adjusted according to the customer requirements.

2.3 TURN ON THE HEAD LIGHT

Press and hold  for 1 seconds can turn on/off the headlight/rear light.

The motor does not work when the battery voltage is low, display still can keep the headlight on for a while when E-bike is in riding.

2.4 6KM PUSH

Press and hold  for 1 seconds can get into 6km push mode, out to the mode when release the button.

HOW TO USE

1. THE PROCESS OF OPENING AND WORKING.

Turn on the power.



B. Turn on the “M” switch button on the display and turn to a level of power which you like and then ride it.



C. Go to ride like normal bicycle.

HOW TO USE

2. THE PROCESS OF CLOSING

- A. Stop ride and keep the bike not moving.
- B. Turn off the “M” switch button on the display.
- C. Turn off the battery.

3. WARNING

Keep the connection(motor and battery)is well and stable before ride.



- B. Don't turn on/off the switch button(battery and display) when you are riding.

BATTERY

1. IMPORTANT SAFETY NOTES CONCERNING THE BATTERY

WARNING

To prolong battery life, store the Ebike in garage to prevent low temperatures and affect the battery performance.

- Do not dismantled or dispersed the battery cells.
- Keep away the battery from children.
- Do not connect cathode and anode of charger during charging and discharge process.
- Prohibited to use any conductor to connect both cathode and anode.
- This will cause short circuit.
- Prohibited battery dip in the water.
- Prohibited placed the battery in the temperature over 60°C next to the high-temperature heat source, such as ingle, heating, etc.
- Prohibited knock on, throwing and trample the batteries, etc.
- Prohibited edge tool or nails lacerate and cut through the battery.
- If the leak occurred, electrolyte has come into the eyes, please do not rub.

Wash immediately with plenty of water

If the battery in smell, heat, smoke, changed colors, distortion or any abnormal, stop using the battery and away from it immediately.

BATTERY

2. PROTECTION

To extend the battery life and be Intelligent Use of li-battery ,here are the regulations:

FIRSTLY: Requirements on charging and discharging

A. CHARGE:

The charger must be the assorted one . First, connect the power to the charger. second,insert the charger's out-put connector to the battery's in-put connector. Third, when the signal light is on,please pull out the battery's in-put connector first. The common single charging time is about 6-8 hours.if the battery be blow-up, the charging or discharging must be stopped.

B. AVOID OVER DISCHARGE:

Charge the battery timely after discharging, in order to avoid the over-discharge.

SECONDLY: Requirements on storage

A . li-battery cannot be stored at the place where is over hot and over humidity,therefore the temperature of the storage should between -20 to 55 degree,and further more the storage must be kept in dry,clean and the battery should not be piled up.

BATTERY

B . the battery cannot be stored for a longtime without charging. The battery should be charged once a month. The battery should be stored with fully charged.

THIRDLY: Maintenance

A . When you test the voltage of the single piece of the battery-cell, you have to test the cell directly ,not by the wire. By doing that, it can avoid the voltage decline.

B . You have to wear the gloves or clip the finger nails before you take out the single piece of the battery. So as to avoid damage the cover of the battery.

C . Forbid bending the battery cell,the top edge of the seal-up.And also the falling ,hitting and short circuit are prohibited.

D . When you re-assemble the battery,there are some special notes we have to concerned in mind. The temperature of the electric iron should below 350x; the welding time must be less than 3 seconds; and the frequency of welding should be no more than 5 times;the second welding must be done after cooling.

CHARGER

1. CHARGER FUNCTION

Trouble shooting:

Should there be any difficulties with charging please check if:

- The power cable is connected properly.
- The charger plug or the battery socket is damaged.
- The battery shows any damage on the surface.
- The power socket works and whether the correct voltage is provided.
(if necessary, plug in another gadget and check).

Please use only the original charger which was supplied with your e-bike.

This charger is specially made for the lithium battery.

The LED light indicates the battery status as shown on the table

Charging cycle and LED indication for lithium battery

LED	Mode
green	the battery is not connected
red	the batter is charging
green	the battery is charged, the charger switches off

2. IMPORTANT SAFETY NOTES CONCERNING THE CHARGE

Before you first use the charger please read the following notes regarding safety carefully!

CHARGER

WARNING

DO NOT OVERCHARGE THE BATTERY.

Overcharging a lithium-ion battery can cause overheating, pressure buildup, and thermal runaway, potentially leading to fire or explosion. It also shortens battery life and degrades capacity over time- Keep the charger away from children

- Keep the charger away from children!
- In order to prevent any possible injury this charger should only be used for the original lithium battery which is supplied together with your e-bike. Any other battery is not compatible and risks to explode while charging, causing serious injury to people as well as damage to other equipment.
- Using this charger for batteries not supplied by MUV Austrália, for the E-bike could risk catching fire, provoke electric shock and/or cause serious injury.
- Please make sure that the charger is always kept dry and does not get wet at any time.
- Should there be an incidence of contact with water or any other liquid, make sure to unplug the charger immediately from the power socket and have it inspected by a specialty dealer
- Make sure the charge is always placed on a flat surface when in use.
- Please make sure that the charger is always unplugged and removed from the power socket when not in use.
- Before using the charger, always make sure that the plug and the cables are not damaged.
- Never connect a damaged cable or plug to the power socket.
- Never try to disassemble the charger. Wrong re-assembling could cause an electric shock and serious injury.
- Always unplug the charger before cleaning it.
- The charger should only be cleaned with a dry cloth. Never use a wet cloth, oil or any other liquid.
- Do not use an extension cable. Only use the original cable supplied with the charger.
- An extension cable might, if not 100 % compatible, catch fire or cause an electric shock.

IMPORTANT NOTICE BEFORE RIDING

- If you're unsure how to assemble your new bike, we recommend seeking assistance from your local bike store.
- Your safety is our top priority. Please follow all safety and maintenance instructions outlined in this manual and in the MUV AUSTRALIA PTY LTD Terms and Conditions available on our website.
- Regular maintenance is essential to ensure your MUV Bike remains in safe riding condition. Always inspect your bike for potential hazards before each ride. Refer to our checklist below for guidance.
- If you're new to electric bikes, practice riding in a spacious, low-traffic area to build confidence before navigating roads or areas with pedestrians.

INITIAL ASSEMBLY AND MONTHLY MAINTENANCE CHECKLIST

ASSEMBLY STEPS

1. Unboxing

- Place the box on a flat surface and open it.
- Remove the bike from the box.
- Stand the bike on its wheels and engage the kickstand.

2. Handlebars Installation

- Remove the black rubber cap and hex socket screw from the fork steering tube.
- Slide on the stem and handlebars.
- Reinstall the hex socket screw and tighten it after aligning the handlebars.

INITIAL ASSEMBLY AND MONTHLY MAINTENANCE CHECKLIST

- Tighten the two stem hex socket screws on each side, ensuring even tension.
- Adjust the handlebar and tight the four screws in a diagonal sequence.

3. Pedals Installation

Check for the “L” and “R” markings on the pedals.

- “L” pedal goes on the LEFT side.
- “R” pedal goes on the RIGHT side.

Important: The left pedal is reverse threaded, meaning it tightens in the opposite direction.

Always check the thread direction before installation to prevent damage, which could make the pedals unusable.

4. Wheels Assembly

The wheel axles are inserted into slots, called “dropouts” in the fork and frame. Examples below:

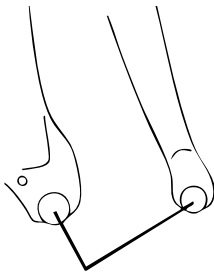

FORK DROPOUT

INITIAL ASSEMBLY AND MONTHLY MAINTENANCE CHECKLIST

Dropouts come in way too many different shapes and sizes to be able to illustrate them all here, but these examples should guide you to identifying where your dropouts are.

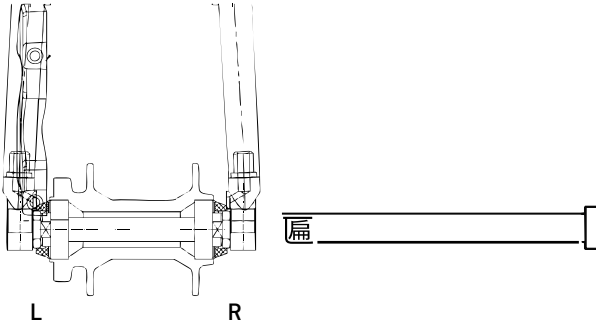

Remove the plastic protector from the front disc brake. Insert the front hub into the wheel and position the wheel onto the fork dropout, ensuring the disc brake is properly aligned and the front hub is securely tightened.

5. Rear and side rack installation

The rear rack is installed on the inner part of the frame and secured with five screws—four on the sides and one underneath. Side racks should be mounted as shown in the picture below.



INITIAL ASSEMBLY AND MONTHLY MAINTENANCE CHECKLIST

6. Position the rear light towards the end of the rear rack.
7. Install the Mid Basket with 4 screws, 2 in each side.
8. Attach the footrest by first removing the screw from the bottom of the rear suspension. Position the footrest in place, then reinsert the screw and tighten it securely.
9. Assemble the turn signal light.
10. Install the mud guards.
11. Install the designated support for the rear derailleur.
12. Inflate the tires to a pressure of 25-30 psi.

Battery Charging:

Ensure the bike is turned off before charging. Charge the battery fully before first use. Once fully charged, unplug it from the charging station. The charger light will change from red to green when fully charged. Note: The charger will function only if connected to the battery before being switched on at the wall socket.

Tyre Pressure:

Check the tyre pressure and ensure it meets the specified range indicated on the tyre sidewall. Do not exceed the maximum pressure.

Tighten Nuts and Bolts:

- Inspect and securely tighten nuts and bolts across the bike, including:
- Front & rear wheel axles, hubs, and spokes.

INITIAL ASSEMBLY AND MONTHLY MAINTENANCE CHECKLIST

- Brake disc rotor bolts (front & rear)
- Brake callipers (front & rear)
- Handlebars
- Forks
- Crank
- General bike bolts

Handlebar Components:

Ensure brake levers, display, buttons, and bells are secure. Avoid overtightening plastic components, as this may cause damage.

Brake Test:

Check that the brakes function properly without leaks or loss of pressure.

Battery Security:

Ensure the battery is securely locked in place using the key mechanism before riding.

Power-On Check:

Make sure the battery's master switch is ON before powering up the bike using the handlebar ON button.

Chain Maintenance:

Ensure the chain is well-lubricated and free of debris.

Battery Terminal Inspection:

Check the battery terminals for debris, corrosion, burn marks, or signs of incorrect contact before fitting the battery.

INITIAL ASSEMBLY AND MONTHLY MAINTENANCE CHECKLIST

Load Capacity:

Do not exceed the bike's maximum load capacity of 120 kg.

Weather Conditions:

Avoid riding in adverse weather conditions such as rain, strong winds, or extreme temperatures above 45°C.

Terrain Usage:

This bike is not designed for mountain terrain. Avoid surfaces that may cause extreme vibrations to the battery pack.

Frame and Wheel Inspection:

Examine the frame and wheels for cracks, weathering, or corrosion.

Safety Gear:

Always wear appropriate safety gear, including an Australian-approved helmet, enclosed shoes, protective clothing, and other necessary equipment.

Traffic Rules:

Familiarize yourself with state road and traffic regulations, and ensure compliance while riding.

Cleaning:

Remove the battery before cleaning. Use a damp cloth, avoiding electrical components. Allow the bike to fully dry before use.

Need Help with Assembly? Watch Our Videos.

WARNING

Improper assembly or use of this electric bike may result in serious injury or death. Always ride responsibly and wear appropriate safety gear.

By purchasing and operating a MUV electric bike, you agree to our Terms and Conditions of Service. To review the full terms, visit:

www.muvaustralia.com.au

Safety Guidelines:

Health & Fitness: Do not ride if you are pregnant, fatigued, unwell, or under the influence of alcohol or drugs. MUV advises that children under the age of 16 should not ride or operate MUV Electric Bikes.

Protective Gear: Always wear an Australian-approved helmet, enclosed hard-sole shoes, and leather gloves as a minimum.

Speed Control: Ride at manageable speeds that allow you to stop safely, even without power or brakes, as these can fail due to low battery, mechanical, or electrical issues.

Road Safety: Avoid riding on busy roads to protect yourself and other road users.

Speed Sensitivity: Higher pedal assist levels (like level 5) can be highly sensitive. Always start at a lower speed level to prevent being thrown off the bike and only ride within your skill level.

Pedestrian Awareness: Always yield to pedestrians and stay aware of your surroundings.

Regular Maintenance: Schedule a bike service every 12 months or 3,000 km, whichever comes first, at your local bike store.

Tyre Pressure & Axle: Regularly check tyre pressure and ensure the front axle is secure.

Mechanical Care: Clean, lubricate, and tighten bike mechanisms regularly. Dirt and debris buildup can reduce battery performance, impact ride quality, or cause failures that may lead to injury.

TERMS & CONDITIONS

ACCEPTANCE OF TERMS

By purchasing from MUV AUSTRALIA PTY LTD, you and anyone you represent agree to be bound by this Agreement. You affirm that you have the authority to accept these terms on behalf of yourself and any other party you represent. If you do not accept these terms or lack the necessary authority, you may not purchase products from MUV AUSTRALIA PTY LTD. These terms apply to all sales of bicycles, clothing, and other products offered by MUV AUSTRALIA PTY LTD.

LIABILITY DISCLAIMER

MUV AUSTRALIA PTY LTD shall not be held liable for any special, indirect, incidental, or consequential damages, even if advised of their possibility. The company is not responsible for accidents, misuse, abuse, loss, or injury involving the rider or third parties, regardless of whether the issue stems from ebike power, speed, improper settings, component defects, or malfunctions. This includes any claims arising from warranty breaches, contracts, torts (including negligence), strict liability, or other causes.

Customers assume full responsibility and liability for all products and components, including but not limited to ebikes, batteries, ebike parts, brakes, mechanical adjustments, electrical wiring, unforeseen events, safety issues, maintenance, and services. They are also fully responsible for understanding the safety concerns and regulations related to the storage, charging, use, and transportation of Li-Ion battery packs.

MUV AUSTRALIA PTY LTD. only ensures quality control of products and components in-house and in manufacturing facilities, including supplier selection for Li-Ion battery packs. Customers must fully understand product maintenance and safe-keeping, including the use of products and components. While our website and manuals provide literature for this purpose, hazard scenarios may extend beyond those foreseen.

TERMS & CONDITIONS

The only recourse under any implied warranty is the replacement or repair of defective parts, which will be of equal or greater value, at the discretion of MUV AUSTRALIA PTY LTD. Except where explicitly prohibited by law, MUV AUSTRALIA PTY LTD shall not be held liable for any property damage, personal injury or death, fire-related incidents, loss of use, opportunity, contracts, goodwill, business interruption, profits, cause and effect losses, or any other consequential, direct, indirect, incidental, special, or punitive damages, whether arising from contract, warranty, negligence, product liability, or any other theory. Ebike riders must comply with all traffic regulations and geographical or age restrictions imposed by State and Federal Governments.

Street Legality

An electric bike described as “Street Legal” means, to the best of our knowledge, it complies with Australian Electric Bike Regulations and is considered a bicycle, not a motorized vehicle. This means it does not require insurance, a license plate, or a driver’s license. However, it is crucial to check your state, federal, and local laws to ensure you are riding legally and safely.

Please note that “Street Legal” does not imply you can ride your electric bike on any bicycle pathways; parks and trails may have their restrictions against the use of electric assist bikes.

MUV AUSTRALIA PTY LTD takes no responsibility for damages, loss, fines, or other consequences from riding the bike on public roads where local rules and regulations do not consider the bike street legal or where it should not be ridden for any reason.

TERMS & CONDITIONS

Shipping Policy

We assure you that your order will be delivered. In the event of a lost item, we will send a replacement at no additional cost. However, we are not liable for dispatch delays, or any delayed or unscheduled deliveries

For bike deliveries, a signature is required upon receipt. If no one is available at the delivery address, a redelivery fee may apply.

In the event of broken or damaged packages, please take photographs and request the courier agent to document and sign a detailed report of the damages. If the product is damaged or lost during shipment, customers may need to assist in completing a claim application as required by the courier service.

Return Policy

This policy applies exclusively to orders placed through our website. For in-store purchases, please refer to the store's specific return policy.

- The customer is responsible for covering return shipping costs.
- Products must be properly repacked in their original packaging. Returns without original packaging will not be eligible for a refund
- If the product is damaged during return due to inadequate packing, repair costs will be the customer's responsibility.
- All returns require prior written approval via email from MUV AUSTRALIA PTY LTD. Unauthorized returns will not be processed.

After-Sales Services

For services not covered under our warranty, we may request proof of

TERMS & CONDITIONS

purchase. If we cannot verify that the requestor is a legitimate buyer of our products, service may be denied.

If you are purchasing a second-hand bike, please ensure you obtain the original proof of purchase from the previous owner.

User-Submitted Content

By submitting thoughts, customer reviews, images, videos, testimonials, technical issues, or service tickets, you grant us and our authorized partners a royalty-free right to use and share this content in any way we deem appropriate.

Errors on Website or Shared Materials

MUV AUSTRALIA PTY LTD is not responsible for any direct or indirect consequences resulting from typographical or illustrative errors on our website, communications, or shared materials. We will correct errors as soon as they are identified.

Delivery and Supply

All delivery and supply times provided are estimates only. MUV AUSTRALIA PTY LTD is not responsible for any delays or failure to meet these estimated dates.

We will make every reasonable effort to fulfill deliveries and provide services within the estimated timeframes

Cancellation

If unforeseen circumstances beyond the Supplier's control prevent the delivery of products or services, the Supplier reserves the right to cancel the Customer's order, even if previously accepted, by providing written notice

TERMS & CONDITIONS

Force Majeure Event

We will make every effort to ensure the supply and delivery of products and services. However, performance may be subject to variation or cancellation due to a Force Majeure Event beyond the Supplier's control, or an inability to procure materials except at increased prices due to such events.

If either the Supplier or Customer is unable to fulfill an obligation (other than payment) due to a Force Majeure Event, that obligation will be suspended for the duration of the event and any reasonable extension thereafter. The affected party must promptly notify the other party of the situation and their inability to perform the obligation.

Definitions:

Customer: The individual or entity, including multiple parties if applicable, purchasing products or services from the Supplier.

Force Majeure Event: An unforeseen event beyond a party's reasonable control that prevents or delays the fulfillment of obligations under these Terms and Conditions, including but not limited to:

Acts of God (e.g., earthquakes, fires, floods, storms, natural disasters)
War, riots, insurrection, vandalism, sabotage, government actions, or embargoes
Epidemics, pandemics
Strikes, labor disputes, or industrial disturbances
Power shortages, equipment breakdowns, or plant failures

Get in Touch

For more information, feel free to email us or submit an inquiry through our contact page admin@muvaustralia.com.au

WARRANTY

Our warranty terms and conditions cover all customers, regardless of whether the products are purchased directly, through dealers, third parties, or second-hand.

If any original component is found to be defective in workmanship within its warranty period, we will repair or replace it. The warranty period for MUV AUSTRALIA PTY LTD is as follows:

- Frame: 2 years / 10,000kms
- Electrical Components: 1 years / 10,000kms (Extension of Warranty for Electrical Components available)

This warranty excludes normal wear and tear, damage caused by improper assembly, accidents, insufficient maintenance, or the installation of parts or accessories. It does not cover damage or failure resulting from accidents, misuse, abuse, or negligence. Any modification to the frame or components will void this warranty. The warranty covers only part replacement and does not include labor or transportation charges. The warranty will become void if the bicycle is used for any purpose other than normal activities, such as not following the owner's manual or using the bike for commercial purposes. The Warrantor may seek reimbursement for any costs incurred if it is found that the product is not defective due to faulty materials or workmanship. The company is not liable for any consequential, special, or cause-and-effect damages. This warranty strictly covers the repair or replacement of defective parts at no charge. It does not include labor or transportation costs. The customer is responsible for delivering the defective product or parts to and from our service center, as well as any third-party service charges (e.g., costs for installing the replacement part at a third-party bike store).

WARRANTY

A bicycle operates under real-world conditions and is subject to various impacts, shocks, vibrations, extreme temperatures, accidents, water exposure, and salt splashes. Such damages are not considered manufacturing faults and are therefore not covered under the warranty. Tyre punctures are not covered by this warranty.

Your electric bike and its components are water-resistant under normal damp or wet conditions. Please note that the bike is water-resistant, not waterproof. It can be ridden in light to moderate rain but should not be submerged in water or ridden in heavy rain showers. The bike should not be washed with a water hose and can only be cleaned with a damp cloth. Damage due to liquid penetration is not covered under the warranty.

Your electric bike and its components are designed to be water-resistant under normal damp or wet conditions. Please keep in mind that while the bike is water-resistant, it is not waterproof. It can be used in light to moderate rain, but it should not be submerged in water or ridden during heavy rain showers. The bike should not be cleaned with a water hose and should only be wiped down with a damp cloth. Damage resulting from liquid penetration is not covered under the warranty.

During the assembly process, adjustments to parts such as brakes and derailleurs may be necessary due to potential movement during shipment. Instructions for making these adjustments can be found on this manual. Improper assembly or failure to adjust parts correctly is not covered under the warranty. Should you choose to have a third-party technician (e.g., a bike shop) perform the assembly or make the necessary adjustments, any incurred fees will not be covered under our warranty. In rare instances, scratches may occur on the bike's paint due to part movement during shipment. Please note that requests for part or bike replacement solely due to scratches on a component or frame will not be accepted.

WARRANTY

If a warranty extension is available for any of our products, you may pay the applicable fees to receive coverage under the same terms and conditions. Applications for the extension must be submitted up to one day before the standard warranty period expires.

The advantages offered by this Product Warranty are in addition to your legal rights associated with the products it covers. The Warrantor's products are covered by guarantees that cannot be excluded under Australian Consumer Law.

Warranty Claims

In the rare event of a fault, please be assured that we will take all reasonable measures to resolve the issue promptly. Customer cooperation is essential for effectively identifying the root cause and addressing the problem.

The seller's technical team will assess the claim and determine if the fault is covered under the warranty. Both parties must abide by the decision of our technical team. If the cause of a fault cannot be reasonably determined, we will cover the cost of replacement or repair in favor of the customer.

We may send you replacement parts such as batteries, motors, LCDs, controllers, etc., to swap and test, with the defective parts being returned. Customers are expected to have some level of technical knowledge or the necessary tools to remotely and safely recover their system with our assistance.

For returns, exchanges, or repairs of parts or products, we do not cover delivery or shipping costs to and from our facilities, nor are we responsible for any associated restrictions. Warranty claims must be submitted directly to the seller via email or the website ticketing system [Warranty Claim](#). If requested, the buyer must provide photos and/or videos of the fault and perform troubleshooting steps, which may sometimes be technical, as directed by the seller. NOTE: Proof of purchase is required.



UNLOCK THE FULL POTENTIAL

OF YOUR WAY TO MUV.



500 Maroochydore rd Kunda, Kunda Park QLD 4556, Australia
Phone +61 447 065 486



@muv_electric



@muv_australia

www.muvaustralia.com.au